

**HD37BT...  
HD37BTV...  
HD377BT...  
HD37V7TV...**



**HD 37BT..., HD 37BTV..., HD 377BT..., HD 37V7TV...  
CO<sub>2</sub>, CO<sub>2</sub> AND TEMPERATURE TRANSMITTERS**

The HD37BT... and HD37VBT... series transmitters are used mainly in air quality control by measuring CO<sub>2</sub> (Carbon Dioxide) in the ventilation systems. This allows you to vary the number of air change per hour according to ASHRAE and IMC norms. The purpose is twofold: to have a good air quality in the presence of people and to save energy, increasing or decreasing parts of air per hour, depending on the air quality set.

The use is for environments where there is overcrowding of people, discontinuous crowding, cafeterias, auditoriums, schools, hospitals, greenhouses, livestock breeding, etc.

The HD377BT... and HD37V7BT... models measure, in addition to CO<sub>2</sub>, also the temperature. **The analog outputs, current 4...20mA or voltage 0...10Vdc, should be specified when ordering.** All transmitters have an alarm digital output suitable to control, for example, an external relay coil. All transmitters have a digital alarm suitable to control eg. an external relay coil. The alarm is activated to pass a threshold set at the factory to 1500ppm, the threshold beyond which a man feels uncomfortable. The sensor element is a particular infrared sensor (NDIR technology: Non-Dispersive Infrared Technology) which, by using a double filter and a particular measurement technique, compensates for the effect of aging thus ensuring accurate and stable measurements over a long time.

The use of a protective membrane, which is spread through the air to be analyzed, minimizes the negative effect of atmospheric dust and the performance of the transmitter. At the entrance of the intake air flow in the transmitter is a filter that you can remove and clean.

The installation methods may be:

- Wall mounted – **TV Version**,
- With power flow horizontally fixed to the container, to be extent ventilation duct – **TO Version**,
- Wall outlet with flow separate with two tubes, connected to the electronics to

the extent ventilation duct – **TC Version**,

In versions with power flow channel and separate electronics, the air is drawn into the measurement chamber. The same flow then returns to the channel through a second tube. **The air flow needs to be at least 1m/s.**

To fix the air inlet to the duct, you can use the HD9008.31 flange, a 3/8" universal biconical fitting or a PG16 metallic fairlead with a Ø 14 mm internal diameter.

The air inlets connected to the transmitter by means of flexible tubes are attached to the channels flowing air: we supply air inlets for square or rectangular ducts (code HD3719) and for circular ducts (code HD3721). In order to maintain the specified accuracy, the cable length should be 1m.

Technical characteristics			Notes
CO <sub>2</sub> Measurement Principle		Double wave length infrared technology (NDIR)	
CO <sub>2</sub> Measurement Range		0 ... 2000ppm 0 ... 5000ppm	
CO <sub>2</sub> Accuracy	f.s. 2000ppm	±(50ppm+3% of measurement)	at 20°C, 50%RH and 1013hPa
	f.s. 5000ppm	±(50ppm+4% of measurement)	
Temperature Measurement Range		0 ... +50°C	Models HD377BT... and HD37V7BT...
Temperature Accuracy		±0.3°C	
Analog Outputs (according to the models)		4 ... 20mA 0 ... 10VDC	R <sub>i</sub> < 500Ω R <sub>i</sub> > 10kΩ
	Type	Open-collector (N.O.)	
Digital Output (all models)	CO <sub>2</sub> Threshold	1500ppm (*)	(*) Factory Preset
	Vmax	40VDC	
	Pmax	400mW	
Power supply		16...40Vdc or 24Vac ±10%	
Absorption		<2W	
Startup Stabilization Time		15 minutes	To guarantee the stated accuracy.
Response Time T <sub>63%</sub>		120s	Wind speed of at least 1m/s.
Temperature effect		0.2%/°C CO <sub>2</sub>	Typical value
Atmospheric Pressure effect		1.6%/kPa	Deviation compared to the value at 101kPa
Long-term Stability		5% of the range / 5 years	Typical value
Calibration		At one point at 0ppm or 400ppm clear air	Automatic detection of the applied CO <sub>2</sub> level.
Working Temperature/Relative Humidity		-5 ... +50°C, 0 ... 95%RH without condensation	
Storage Temperature/Relative Humidity		-10 ... +60°C, 0 ... 95%RH without condensation	
Electronics Protection Degree		IP21	Wall mounted models (TV).
		IP65	Horizontal probe models (TO), probe excluded.
		IP65	Separate probe models (TC), probe excluded.
Case size		80x84x44	Probe excluded.
Case material		ABS	

**Model description**

Model	Type of output		Measured quantities	
	4 ... 20mA	0 ... 10Vdc	CO <sub>2</sub>	Temperature
HD37BT...	✓		✓	
HD37VBT...		✓	✓	
HD377BT...	✓		✓	✓
HD37V7BT...		✓	✓	✓

Model	Probe	CO <sub>2</sub> Measurement Range
...BTV	Wall mounted model	0...2000ppm
...BTV.1	Wall mounted model	0...5000ppm
...BTO.1	CO <sub>2</sub> model with horizontal air inlet L=115mm CO <sub>2</sub> /temperature model with horizontal air inlet L=120mm	0...2000ppm
...BTO.11	CO <sub>2</sub> model with horizontal air inlet L=115mm CO <sub>2</sub> /temperature model with horizontal air inlet L=120mm	0...5000ppm
...BTO.2	CO <sub>2</sub> model with horizontal air inlet L=315mm CO <sub>2</sub> /temperature model with horizontal air inlet L=320mm	0...2000ppm
...BTO.21	CO <sub>2</sub> model with horizontal air inlet L=315mm CO <sub>2</sub> /temperature model with horizontal air inlet L=320mm	0...5000ppm
...BTC	Wall mounted model with attachments for an air inlet separate from the duct	0...2000ppm
...BTC.1	Wall mounted model with attachments for an air inlet separate from the duct	0...5000ppm

## Calibration

The instruments are calibrated at the factory and do not usually require further action by the user.

However, it is possible to perform a new calibration that corrects the sensor offset:

- (approx. 400ppm) in clean air
- to 0ppm with nitrogen bottles (code MINICAN.20A).

The instrument is able to recognize automatically the calibration methods used: whether 400ppm or 0ppm. The calibration should be performed one point only: each new calibration cancels the previous one.

Proceed as follows:

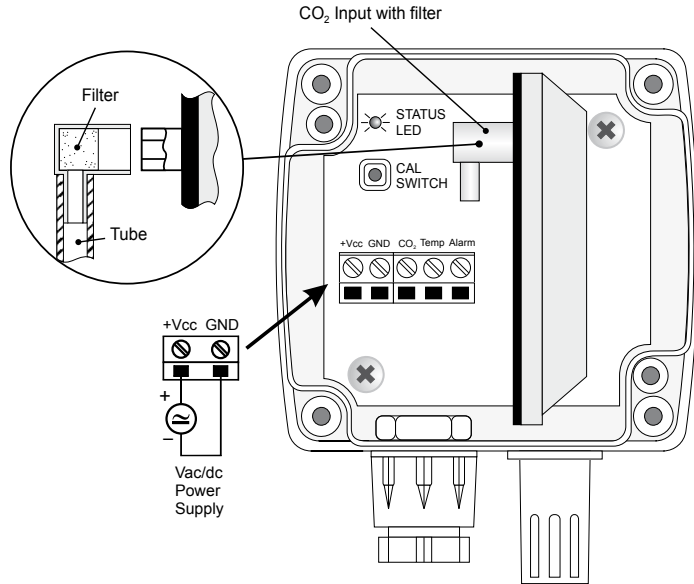

Open the instrument top cover to discover the CAL SWITCH calibration key on the board and the calibration gas inlet.

1. Let open the entrance if you want to calibrate around 400ppm: in which case, be sure to attach the instrument clean air.
2. For a calibration at 0ppm, connect the tube from the nitrogen bottle to the CO<sub>2</sub> input. Adjust the bottle flow meter on a flow from 0.3 to 0.5l/min.
3. Power up the instrument according to specifications and wait at least 15 minutes before proceeding.
4. Supply CO<sub>2</sub> for at least 2 minutes so as to stabilize the measurement.
5. Continue to provide CO<sub>2</sub> to the instrument, hold the CAL SWITCH key pressed for at least 5 seconds until the STATUS LED flashes: the two-minute calibration starts. At this stage the instrument is calibrated to measure CO<sub>2</sub> and a value close to 0ppm, if you use the nitrogen cylinder, to 400ppm, if you calibrate to clean air.
6. Wait the **two minutes** necessary for calibration without changing the working conditions.
7. When the LED turns off, the calibration is completed.



HD37VBT

## Installation Notes

The choice of the number of CO<sub>2</sub> transmitters to be used in a typical installation and location, should be based on the fact that the distribution CO<sub>2</sub> in the atmosphere is influenced by the same factors that determine temperature distribution. Among these factors are convection, diffusion and forced air movement in the environment.

For an accurate control, you should use a CO<sub>2</sub> transmitter (TV model) in any place where there is a temperature control. You can also opt for a single device (TO or TC model) installed at the point of air quality control.

*For the wall mounted TV models*

The transmitter has to be installed into a location with good air circulation, away from doors, windows or entry points of fresh air from outside. The height from the floor should be at least 1.5 meters.

*For the TO models with horizontal air inlet from the duct*

- The transmitter should be installed so that the air inlet is correctly oriented with the flow into the channel. In the probe head there is an arrow indicating the correct direction of airflow. To facilitate installation, on the left side face of the container, **near the air input to the sensor**, is engraved with the following symbol.

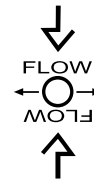

- To set the probe into a duct, with flat surface (square or rectangular), use the HD9008.31.12 flange, a PG16 metallic fairlead with  $\varnothing$  14 mm internal hole, or a 3/8" biconical universal fitting with  $\varnothing$  14 mm internal hole.

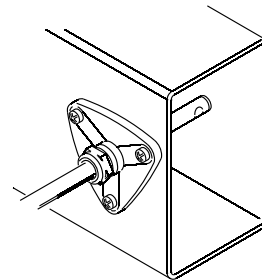

HD9008.31 flange

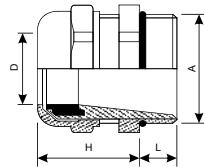

PG16 metallic fairlead  
D = 10...14mm  
L = 6.5mm  
H = 23 mm  
A = PG16

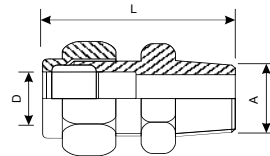

Biconical universal fitting  
L = 35 mm  
D = 14 mm  
A = 3/8"

*For the TC models with air inlet separate from electronics*

We have two probes: One (code HD3719) for flat walls ducts (square or rectangular section), another (code HD3721) for circular section ducts. Please see the following figure.

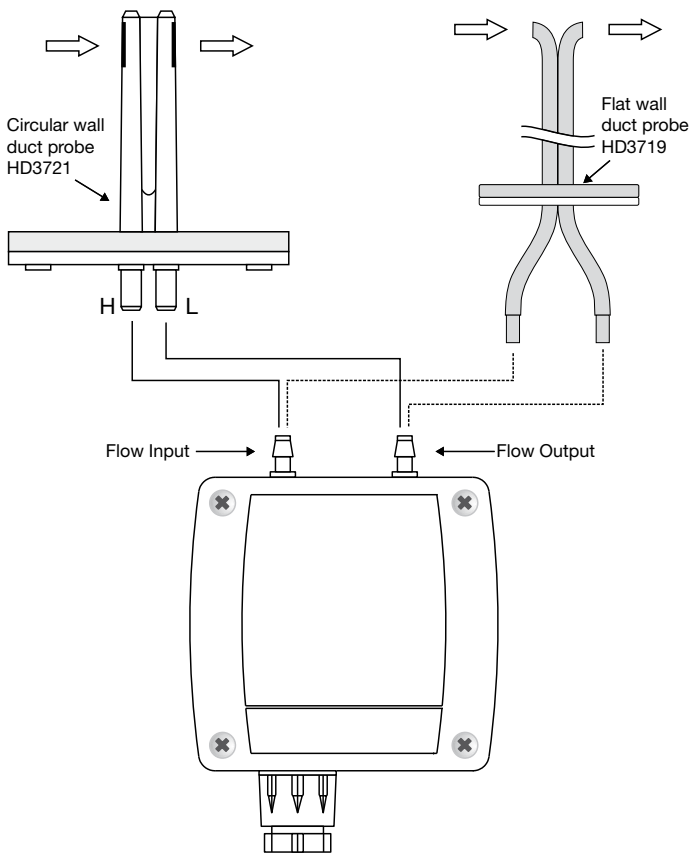

The duct air inlet should be oriented so that the flow enters from the entrance connected to the junction on the left in the container leaving from the right one.

### Electrical connections

#### Power supply

Supply the instrument with the voltage according to what indicated in the technical characteristics: the power supply terminals are indicated by +Vdc and GND.

#### Analog Outputs

The output signal is acquired, depending on model:

- Between the CO<sub>2</sub> and GND terminals for CO<sub>2</sub> transmitters,
- Between the CO<sub>2</sub> and GND, Temp and GND terminals for CO<sub>2</sub> and temperature transmitters,

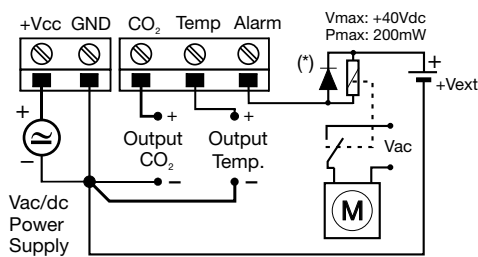

HD37BTC

### Digital Output

The diagram shows an example of application for a digital output that controls, in this case, an **external relay** coil. When exceeding the alert threshold (1500ppm), the relay contact closes and activates an adjustment device.

(\*) **Warning:** Protect the digital output by applying a protection diode as shown in the figure.

Do not exceed the maximum reverse voltage and power limits indicated in the technical information.

### HD37BTV / HD377BTV sizes

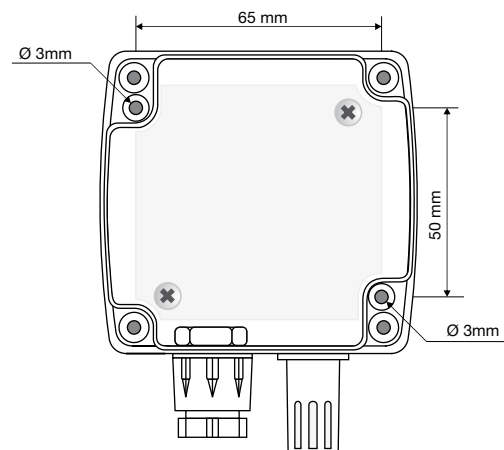
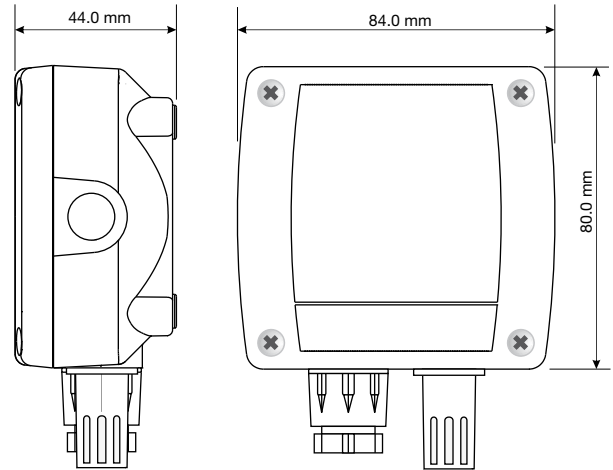

### Drilling template

#### Duct air inlet sizes

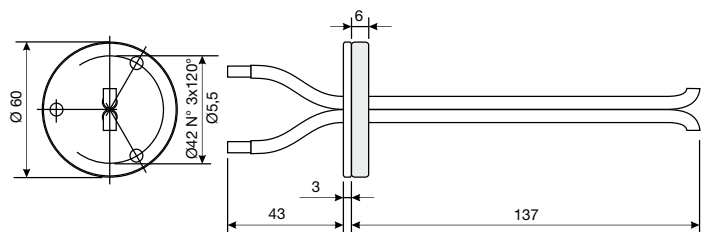
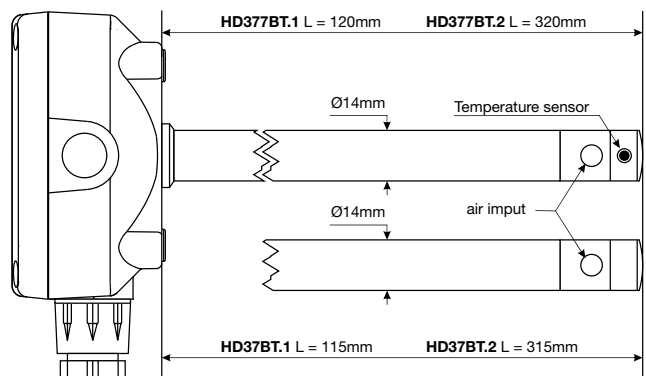

HD3719 Duct Probe

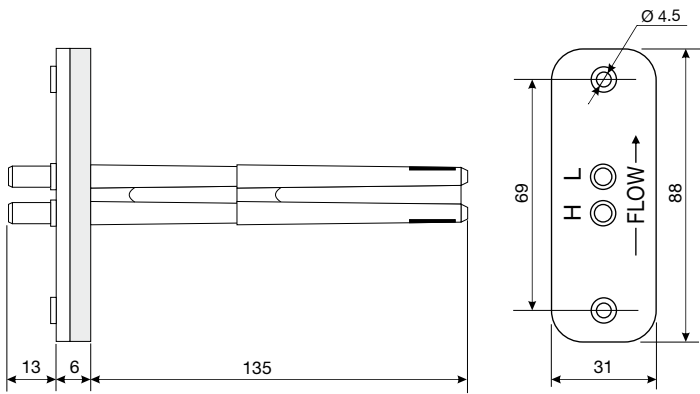

AP3721 Duct Probe

#### Purchasing codes

**HD37BT...: CO<sub>2</sub> active transmitter, analog output 4...20mA.** Power supply 16...40VDC or 24VAC. Functioning temperature -5°C ... +50°C. Alarm digital output for levels of CO<sub>2</sub> > 1500ppm.

**HD37BTBV:** Wall mounted one-piece version. CO<sub>2</sub> Measurement Range 0...2000ppm.

**HD37BTB1.1:** Wall mounted one-piece version. CO<sub>2</sub> Measurement Range 0...5000ppm.

**HD37BT0.1:** Duct version with horizontal air inlet in AISI 304 steel diameter 14mm, L=115mm. CO<sub>2</sub> Measurement Range 0...2000ppm.

**HD37BT0.11:** Duct version with horizontal air inlet in AISI 304 steel diameter 14mm, L=115mm. CO<sub>2</sub> Measurement Range 0...5000ppm.

**HD37BT0.2:** Duct version with horizontal air inlet in AISI 304 steel diameter 14mm, L=315mm. CO<sub>2</sub> Measurement Range 0...2000ppm.

**HD37BT0.21:** Duct version with horizontal air inlet in AISI 304 steel diameter 14mm, L=315mm. CO<sub>2</sub> Measurement Range 0...5000ppm.

**HD37BTB1C:** Wall mounted one-piece version with attachments for an air inlet separate from the duct CO<sub>2</sub> Measurement Range 0...2000ppm.

**HD37BTB1.1:** Wall mounted one-piece version with attachments for an air inlet separate from the duct CO<sub>2</sub> Measurement Range 0...5000ppm.

**HD37VBT...: CO<sub>2</sub> active transmitter, analog output 0...10VDC.** Power supply 16...40VDC or 24VAC. Functioning temperature -5°C ... +50°C. Alarm digital output for levels of CO<sub>2</sub> > 1500ppm.

**HD37VBTBV:** Wall mounted one-piece version. CO<sub>2</sub> Measurement Range 0...2000ppm.

**HD37VBTB1.1:** Wall mounted one-piece version. CO<sub>2</sub> Measurement Range 0...5000ppm.

**HD37VBT0.1:** Duct version with horizontal air inlet in AISI 304 steel diameter 14mm, L=115mm. CO<sub>2</sub> Measurement Range 0...2000ppm.

**HD37VBT0.11:** Duct version with horizontal air inlet in AISI 304 steel diameter 14mm, L=115mm. CO<sub>2</sub> Measurement Range 0...5000ppm.

**HD37VBT0.2:** Duct version with horizontal air inlet in AISI 304 steel diameter 14mm, L=315mm. CO<sub>2</sub> Measurement Range 0...2000ppm.

**HD37VBT0.21:** Duct version with horizontal air inlet in AISI 304 steel diameter 14mm, L=315mm. CO<sub>2</sub> Measurement Range 0...5000ppm.

**HD37VBTB1C:** Wall mounted one-piece version with attachments for an air inlet separate from the duct CO<sub>2</sub> Measurement Range 0...2000ppm.

**HD37VBTB1.1:** Wall mounted one-piece version with attachments for an air inlet separate from the duct CO<sub>2</sub> Measurement Range 0...5000ppm.

**HD377BT...: CO<sub>2</sub> and temperature active transmitter, analog output 4...20mA.** Temperature range 0...+50°C, non-modifiable. Power supply 16...40VDC or 24VAC. Functioning temperature -5°C ... +50°C. Alarm digital output for levels of CO<sub>2</sub> > 1500ppm.

**HD377BTBV:** Wall mounted one-piece version. CO<sub>2</sub> Measurement Range 0...2000ppm.

**HD377BTB1.1:** Wall mounted one-piece version. CO<sub>2</sub> Measurement Range 0...5000ppm.

**HD377BT0.1:** Duct version with horizontal air inlet in AISI 304 steel diameter 14mm, L=120mm. CO<sub>2</sub> Measurement Range 0...2000ppm.

**HD377BT0.11:** Duct version with horizontal air inlet in AISI 304 steel diameter 14mm, L=120mm. CO<sub>2</sub> Measurement Range 0...5000ppm.

**HD377BT0.2:** Duct version with horizontal air inlet in AISI 304 steel diameter 14mm, L=320mm. CO<sub>2</sub> Measurement Range 0...2000ppm.

**HD377BT0.21:** Duct version with horizontal air inlet in AISI 304 steel diameter 14mm, L=320mm. CO<sub>2</sub> Measurement Range 0...5000ppm.

**HD37V7BT...: CO<sub>2</sub> and temperature active transmitter, analog outputs 0...10VDC.** Temperature range 0...+50°C, non-modifiable. Power supply 16...40VDC or 24VAC. Functioning temperature -5°C ... +50°C. Alarm digital output for levels of CO<sub>2</sub> > 1500ppm.

**HD37V7BTBV:** Wall mounted one-piece version. CO<sub>2</sub> Measurement Range 0...2000ppm.

**HD37V7BTB1.1:** Wall mounted one-piece version. CO<sub>2</sub> Measurement Range 0...5000ppm.

**HD37V7BT0.1:** Duct version with horizontal air inlet in AISI 304 steel diameter 14mm, L=120mm. CO<sub>2</sub> Measurement Range 0...2000ppm.

**HD37V7BT0.11:** Duct version with horizontal air inlet in AISI 304 steel diameter 14mm, L=120mm. CO<sub>2</sub> Measurement Range 0...5000ppm.

**HD37V7BT0.2:** Duct version with horizontal air inlet in AISI 304 steel diameter 14mm, L=320mm. CO<sub>2</sub> Measurement Range 0...2000ppm.

**HD37V7BT0.21:** Duct version with horizontal air inlet in AISI 304 steel diameter 14mm, L=320mm. CO<sub>2</sub> Measurement Range 0...5000ppm.

**HD9008.31:** Wall flange with fairlead for Ø 14mm probe mounting.

**PG16:** Metallic fairlead for Ø 14mm probes.

**HD3719:** Air inlet for square or cylindrical ducts. Two 1 m tube segments Ø3.2/Ø6.4. For ...BTC and ...BTC.1 models.

**HD3721:** Air inlet for cylindrical ducts, in plastic material. Two 1 m tube segments Ø3.2/Ø6.4. For ...BTC and ...BTC.1 models.

**MINICAN.20A:** Nitrogen bottle for CO<sub>2</sub> at Oppm calibration. Volume 20 liters. With adjustment valve.

**MINICAN.20A1:** Nitrogen bottle for CO<sub>2</sub> at Oppm calibration. Volume 20 liters. Without adjustment valve.

**T37...m:** PVC Crystal tube Ø int. 3,2mm / Ø ext. 6,4mm, length upon request.



#### Order codes for CO<sub>2</sub> transmitters

HD37 **X** **B** **T** **X** **X**

**No sign** = Range CO<sub>2</sub> 0...2000ppm.  
**1** = Range CO<sub>2</sub> 0...5000ppm.

**V** = Wall mounted  
**0.1** = 115mm air inlet from ducts  
**0.2** = 315mm air inlet from ducts  
**C** = Separate probe from ducts

**B** = CO<sub>2</sub> output

**No sign** = Analog output 4...20mA  
**V** = Analog output 0...10Vdc

#### Order codes for CO<sub>2</sub> and temperature transmitters

HD37 **X** **7B** **T** **X** **X**

**No sign** = Range CO<sub>2</sub> 0...2000ppm.  
**1** = Range CO<sub>2</sub> 0...5000ppm.

**V** = Wall mounted  
**0.1** = 120mm air inlet from ducts  
**0.2** = 320mm air inlet from ducts

**B** = CO<sub>2</sub> output  
**7** = Temperature output

**No sign** = Analog output 4...20mA  
**V** = Analog output 0...10Vdc