



**NIEUWKOOP**

# USER MANUAL



## TP1200

INFRARED TEMPERATURE METER

-50...+800°C



TO MEASURE  TO KNOW



INDEX

1	INTRODUCTION.....	3
2	SAFETY INSTRUCTIONS.....	3
3	SUPPLY/EQUIPMENT AND USE.....	4
4	FEATURES.....	4
5	USE	
5.1	Description.....	4
5.2	Functional design.....	5
5.3	Switching °C/°F.....	5
5.4	Max.....	5
5.5	Measurement operation.....	6
5.6	Distance & spot size.....	6
5.7	Measurement considerations.....	6
5.8	How it works.....	7
5.8.1	Field of view.....	7
5.8.2	Distance & spot size.....	7
5.8.3	Locating a hot spot.....	7
5.8.4	Reminders.....	7
5.9	Emissivity.....	7
5.10	Battery replacement.....	8
6	SPECIFICATIONS.....	8
7	EXPLANATION SYMBOLS.....	9
8	DISPOSAL.....	9
9	MAINTENANCE AND CLEANING.....	9

**Fig. A**



**Fig. B**

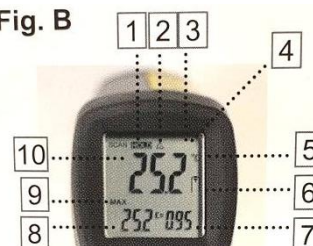

**Fig. C**





## 1 INTRODUCTION

Thank you for the purchase of the IR Thermometer. This is capable of non-contact (infrared) temperature measurements at the touch of a button. The built-in laser pointer increases target accuracy while the backlight LCD and handy push-buttons combine for convenient, ergonomic operation.

The non-contact infrared thermometer can be used to measure the temperature of objects' surface that is improper to be measured by traditional (contact) thermometer (such as moving object, the surface with electricity current or the objects which are uneasy to be touched).

Proper use and care of this meter will provide years of reliable service.

## 2 SAFETY INSTRUCTIONS

- Check if the contents of the packaging is undamaged and complete
- Remove the protective film from the display
- Thermometer may only be used as described in these instructions
- Unauthorized repairs, modifications or changes to the product are not permitted
- Never point the beam at anyone's eyes
- Keep the meter and batteries away from children
- Batteries must not be thrown into an open flame, short-circuited, disassembled or recharged  
Explosion danger!
- Batteries contain harmful acids. Exhausted batteries should be replaced as soon as possible to prevent damage caused by leaks
- Never use a combination of old and new batteries, or different types of batteries. Wear chemical-resistant protective gloves and safety glasses when working with leaking batteries
- Remove the battery when the device is not used for a long time
- The lens should be kept clean at all times
- The sensor lens is the most vulnerable part of the device. The lens should be kept clean at all times, care must be taken when lens is cleaned using only a soft cloth or cotton swab with water or medical alcohol, and make sure the lens is completely dry before use of the device.
- Do not leave the device near objects with a high temperature
- Store the measuring instrument in a dry and clean place
- Avoid impact to the device
- No responsibility is taken for deviating or incomplete measured values and their results, liability for consequential damage is excluded
- Do not use the device in an explosive area. This is life threatening!





### 3 SUPPLY/EQUIPMENT AND USE

- Infrared thermometer
- Optional: belt bag
- ABS suitcase
- 9V battery
- User manual

### 4 FEATURES

- Rapid detection function
- Precise non-contact measurements
- Dual lasering sighting
- Unique flat surface, modern housing design
- Automatic data hold
- °C/°F switch
- Emissivity digitally adjustable from 0.10 to 1.0
- MAX temperature displays
- Backlight LCD display
- Automatic selection range and display resolution 0.1°C (0.1°F)
- Trigger lock
- Set high and low alarms

### 5 USE

#### 5.1 Description

Fig. A (see page 2)

##### Front panel

- |                                   |                        |
|-----------------------------------|------------------------|
| 1. IR sensor                      | 5. Mode button         |
| 2. LCD display Laser pointer beam | 6. Measurement trigger |
| 3. "Up" button ↑                  | 7. Battery cover       |
| 4. "Down" button ↓                | 8. Handle grip         |

Fig. B (see page 2)

##### Indicator

- |                                    |                                   |
|------------------------------------|-----------------------------------|
| 1. Data hold                       | 6. Low battery symbol             |
| 2. Laser "active" symbol           | 7. Emissivity symbol and value    |
| 3. Lock symbol                     | 8. Temperature values for the MAX |
| 4. High alarm and low alarm symbol | 9. Symbols for MAX                |
| 5. °C/°F symbol                    | 10. Current temperature value     |

Fig. C (see page 2)

##### Buttons

1. "Up" button (for EMS, HAL, LAL
2. "Down" button (for EMS HAL, LAL
3. Mode button (for cycling through the mode loop



## 5.2 Functional design

1. Slide switch for °C / °F switching in the battery compartment
2. In the measuring time, use the “up” and “down” keys to adjust emissivity
3. In the hold time, use the “up” key to turn on/off the laser. Use the “down” key to turn on/off the backlight
4. To set values for the High Alarm (HAL), Low Alarm (LAL) and Emissivity (EMS), press the MODE button until the appropriate code appears in the display. Press the “up” and “down” buttons to adjust the desired values.

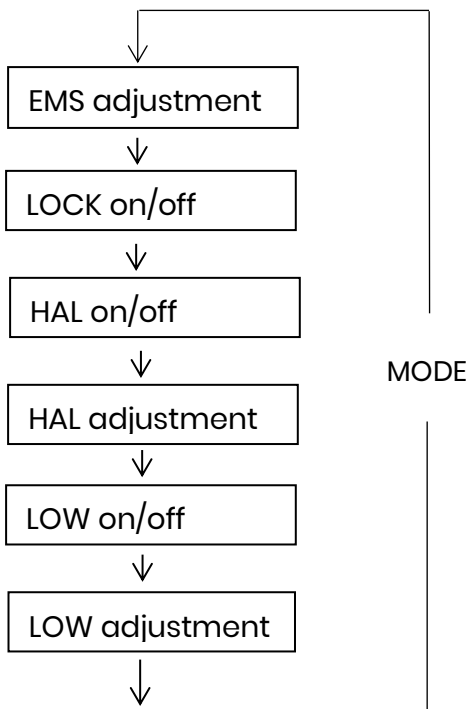

### MODE button function

The mode button also allows you to access the SET state, Emissivity (EMS), Lock on/off, HAL adjustment, LOW on/off, LOW adjustment. Each time you press set, you advance through the mode cycle. The diagram shows the sequence of functions in the mode cycle.

### EMS aanpassing

The emissivity is adjustable from 0.10 to 1.0, LOCK on/off. The lock mode is particularly useful for continuous monitoring of temperatures. Press the “up” or “down” button to turn on or off. Press the measurement trigger to confirm the lock measurement mode. The TP1200 will continuously

display the temperature until the measurement trigger is pressed again. In lock mode, press the “up” or “down” button to adjust the emissivity. HAL (LOW) on/off. Press the “up” or “down” button to turn on or off. Press the measurement trigger to confirm the high (low) alarm mode. HAL (LOW) adjustment. The high (low) alarm is adjustable from -50 to +800°C (-58 ~ 1472°F).

## 5.3 Switching between °C/°F

Select the temperature units (°C or °F) using the °C/°F switch. This switch can be found in the battery compartment (1)

## 5.4 Max

Indicate the max record that displays between the pressing and releasing of the “ON/OFF” button each time.

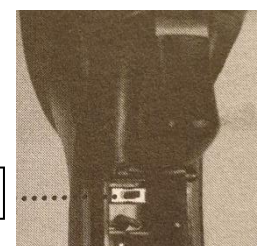

1



### 5.5 Measurement operation

1. Hold the meter by its handle grip and point it towards the surface to be measured.
2. Press and hold the trigger to turn the meter on and begin testing. The display will light up if the battery is good. Replace the battery if the display does not light up.
3. Release the trigger and the hold icon will appear on the LCD indicating that the reading is being held. In HOLD status, press the UP button to turn on or off the laser. Press the DOWN button to turn of or off the backlight.
4. The meter will automatically power off after approximately 7 seconds after the trigger is released. (Unless the unit is locked on).

### 5.6 Distance & spot size

As the distance (D) from the object increases, the spot size (S) of the area measured by the unit becomes larger. The relationship between distance and spot size for each unit is listed below. The focal point for each unit is 914 mm (36"). The spot size indicates 90% encircled energy.

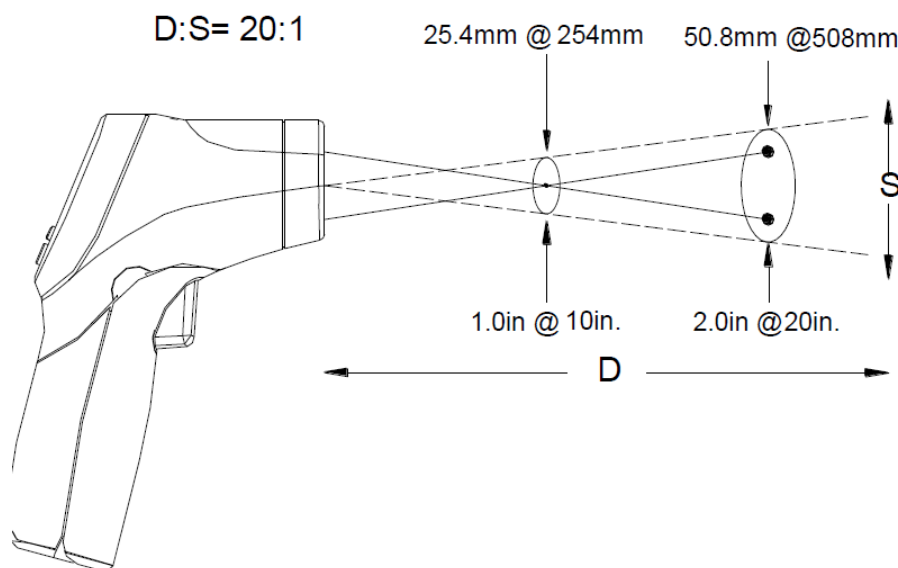

### 5.7 Measurement considerations

Holding the meter by its handle, point the IR sensor towards the object whose temperature is to be measured. The meter automatically compensates for temperature deviations from ambient temperature. Keep in mind that it will take up to 30 minutes to adjust to wide ambient temperatures are to be measured followed by high temperature measurements, some time (several minutes) is required after the low (and before the high) temperature measurements are made. This is a result of the cooling process, which must take place for the IR sensor.



## **5.8 How it works**

Infrared thermometers measure the surfaced temperature of an object.

The unit's optics sense emitted, reflected and transmitted energy which is collected and focused onto a detector. The unit's electronics translate the information into a temperature reading, which is displayed on the unit. In units with a laser, the laser is used for aiming purposes only.

### **5.8.1 Field of view**

Make sure that the target is larger than the unit's spot size. The smaller the target, the closer you should be to it. When accuracy is critical, make sure the target is at least twice as large as the spot size.

### **5.8.2 Distance & spot size**

As the distance (D) from the object increases, the spot size (S) of the area measured by the unit becomes larger (see page 6).

### **5.8.3 Locating a hot spot**

To find a hot spot aim the thermometer outside the area of interest, then scan across with an up and down motion until you locate hot spot.

### **5.8.4 Reminders**

1. Not recommended for use in measuring shiny or polished metal surfaces (stainless steel, aluminum, etc.). See emissivity.
2. The unit cannot measure through transparent surfaces such as glass. It will measure the surface temperature of the glass instead.
3. Steam, dust, smoke, etc. can prevent accurate measurement because of obstructing the unit's optics.

## **5.9 Emissivity**

Emissivity is a term used to describe the energy-emitting characteristics of materials.

Most (90% of typical applications) organic materials and painted or oxidized surfaces have an emissivity of 0.95 (pre-set in the unit). Inaccurate readings will result from measuring shiny or polished metal surfaces. To compensate, cover the surface to be measured with masking tape or flat black paint. Allow time for the tape to reach the same temperature as the material underneath it. Measure the temperature of the tape or painted surface.



Emissivity values

Substance	Thermal emissivity	Substance	Thermal emissivity
Asphalt	0.90 ... 0.98	Cloth (black)	0.98
Concrete	0.94	Human skin	0.98
Cement	0.98	Leather	0.75 tot 0.80
Sand	0.90	Charcoal (powder)	0.96
Earth	0.92 ... 0.96	Lacquer	0.80 ... 0.95
Water	0.92 ... 0.96	Lacquer (matt)	0.97
Ice	0.96 ... 0.98	Rubber (black)	0.94
Snow	0.83	Plastic	0.85 ... 0.95
Glass	0.90 ... 0.95	Timber	0.90
Ceramic	0.90 ... 0.94	Paper	0.70 ... 0.94
Marble	0.94	Chromium oxides	0.81
Plaster	0.80 ... 0.90	Copper oxides	0.78
Mortar	0.89 ... 0.91	Iron oxides	0.78 ... 0.82
Brick	0.93 ... 0.96	Textiles	0.90

**5.10 Battery replacement**

1. As the battery voltage is not sufficient, the LCD will display “”.  
Replacement with one new battery type 9V is required.
2. Open the battery cover, then take out the battery from the instrument and replace with a new 9V battery and place the battery cover back.

**6 SPECIFICATIONS**

Range	-50°C...+800°C / -58°F...+1472°F
D:S	20:1
Display resolution	0.1°C (0.1°F)
Response time	150ms
Spectral response	8-14um
Emissivity	Digitally adjustable from 0.10 to 1.0
Over range indication	LCD will show “----”, “-OL”, “OL”
Diode laser	Output <1mW, Wavelength 630-670nm, Class II laser product
Operating temperature	0...50°C (32...122°F)
Storage temperature	-10...60°C (-14...140°F)
Relative Humidity	10% ~ 90%RH operating, <80%RH storage
Power supply	9V battery, NEDA 1604A of IEC 6LR61, or equivalent
Weight	300g (incl. package)
Dimensions	146 x 104 x 43mm
Safety	“CE” comply with EMC





## 7 EXPLANATION SYMBOLS



This marking means that the product complies with the applicable regulations within the European Economic Area and has been tested according to the specified test methods

## 8 DISPOSAL



This product must not be disposed of with household waste. The user is obliged to hand over the equipment to an approved deposit point for the disposal of electrical and electronic equipment to ensure environmentally sound disposal.



## 9 MAINTENANCE AND CLEANING

- Repairs or service are not covered in this manual and should only be carried out by qualified trained technicians.
- Periodically, wipe the body with a dry cloth. Do not use abrasives or solvents on this instrument.
- No part of the device should be submerged..
- Never use solvents to clean the lens.
- For service, use only manufacturer's specified parts.



TO MEASURE  TO KNOW

**Nieuwkoop BV**

Aalsmeerderweg 249 -S

1432 CM AALSMEER

0297 325836

[info@nieuwkoopbv.nl](mailto:info@nieuwkoopbv.nl)

[www.meten.nl](http://www.meten.nl)



**NIEUWKOOP**